

BERMUDA

PREMIUM PANELS INC.

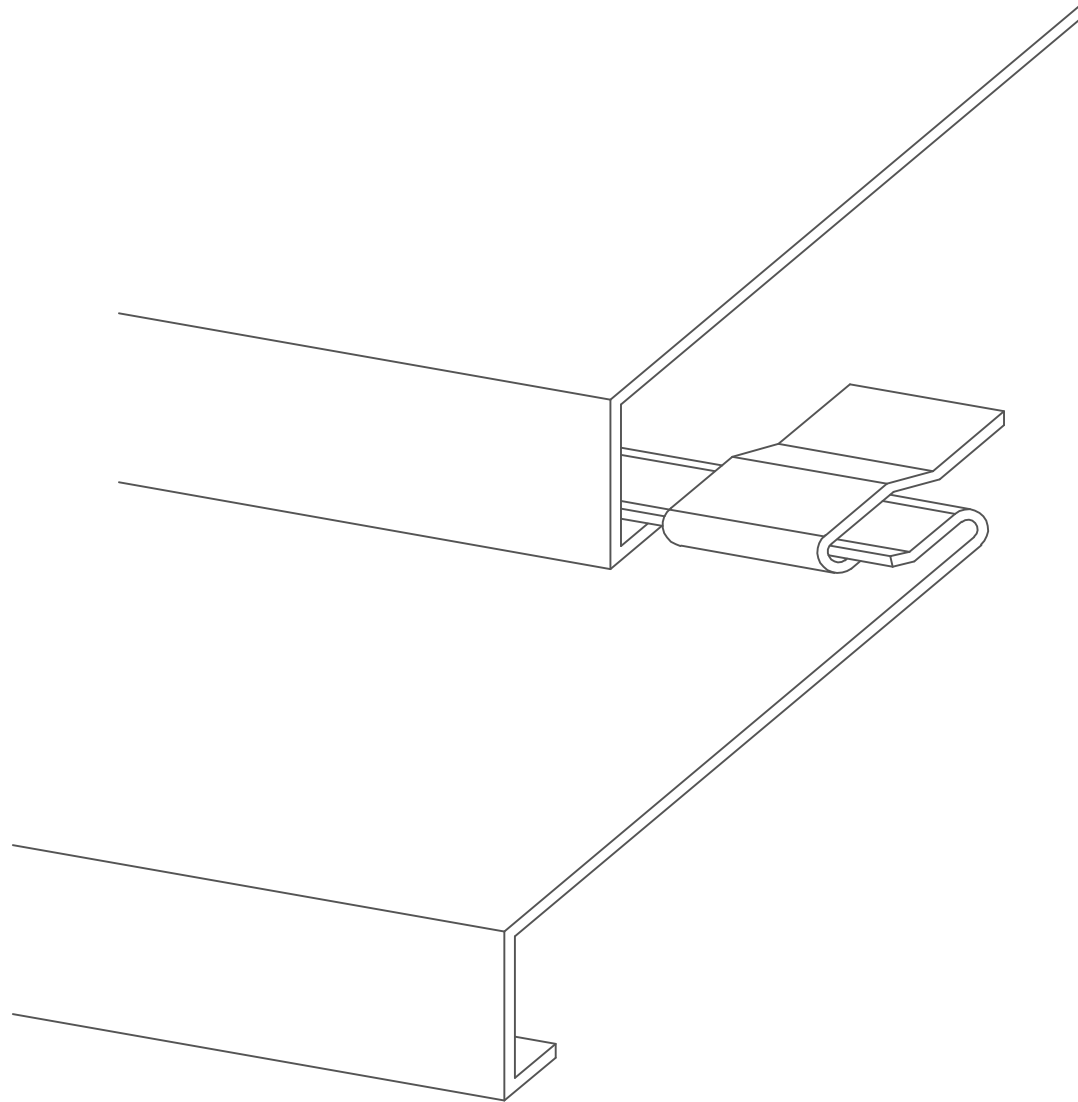

PLYWOOD DECK DETAILS

NOTES:

-MATERIAL USAGE: 1" = APPROX. 2⁵/₁₆"
1 1/2" = APPROX. 2¹³/₁₆"

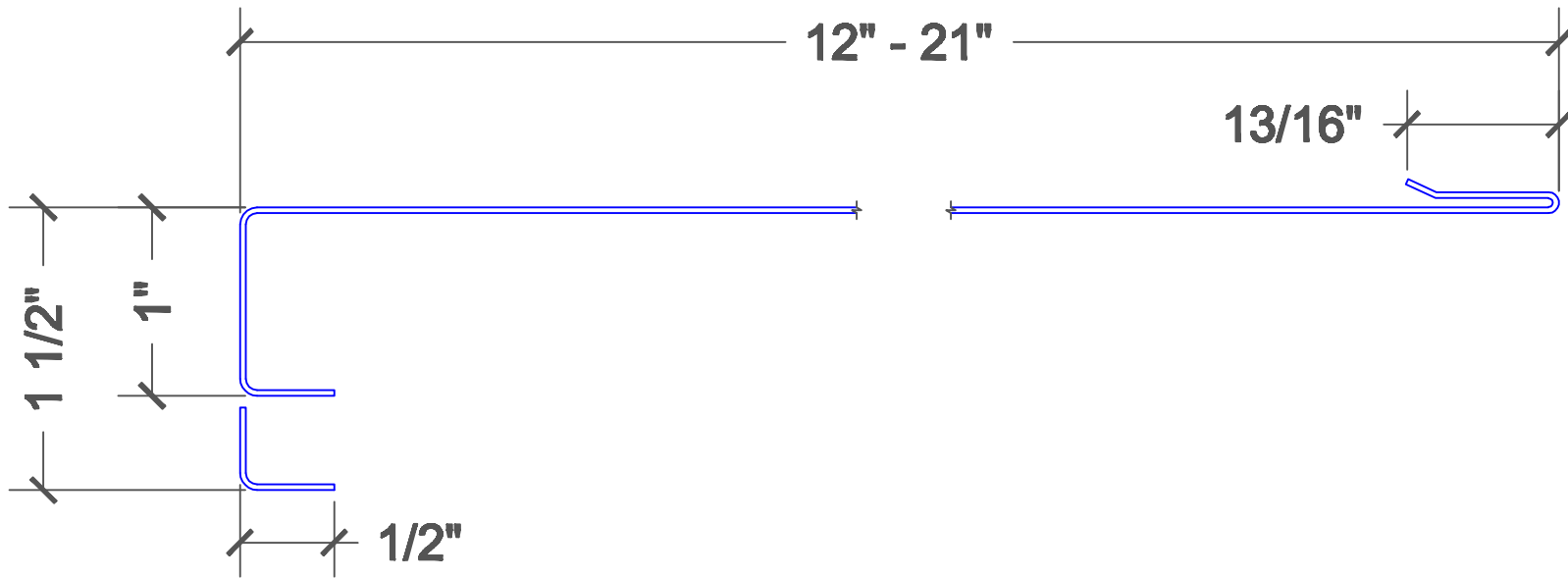
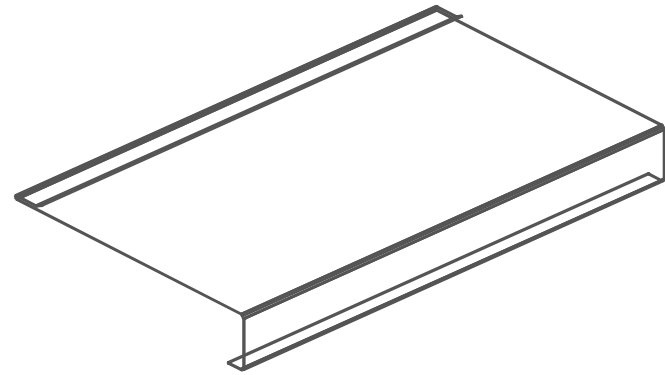

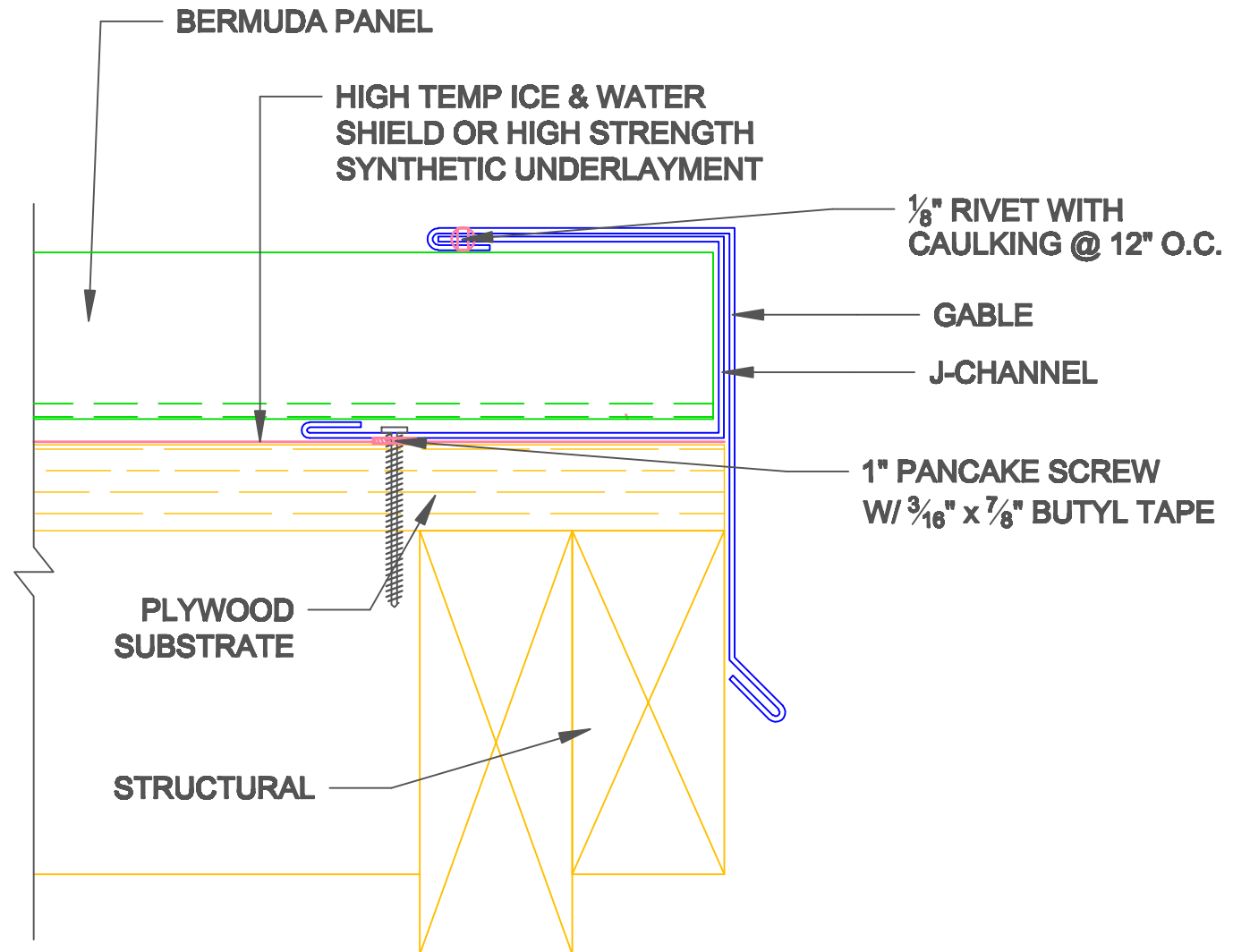

BERMUDA GABLE W/ J-CHANNEL

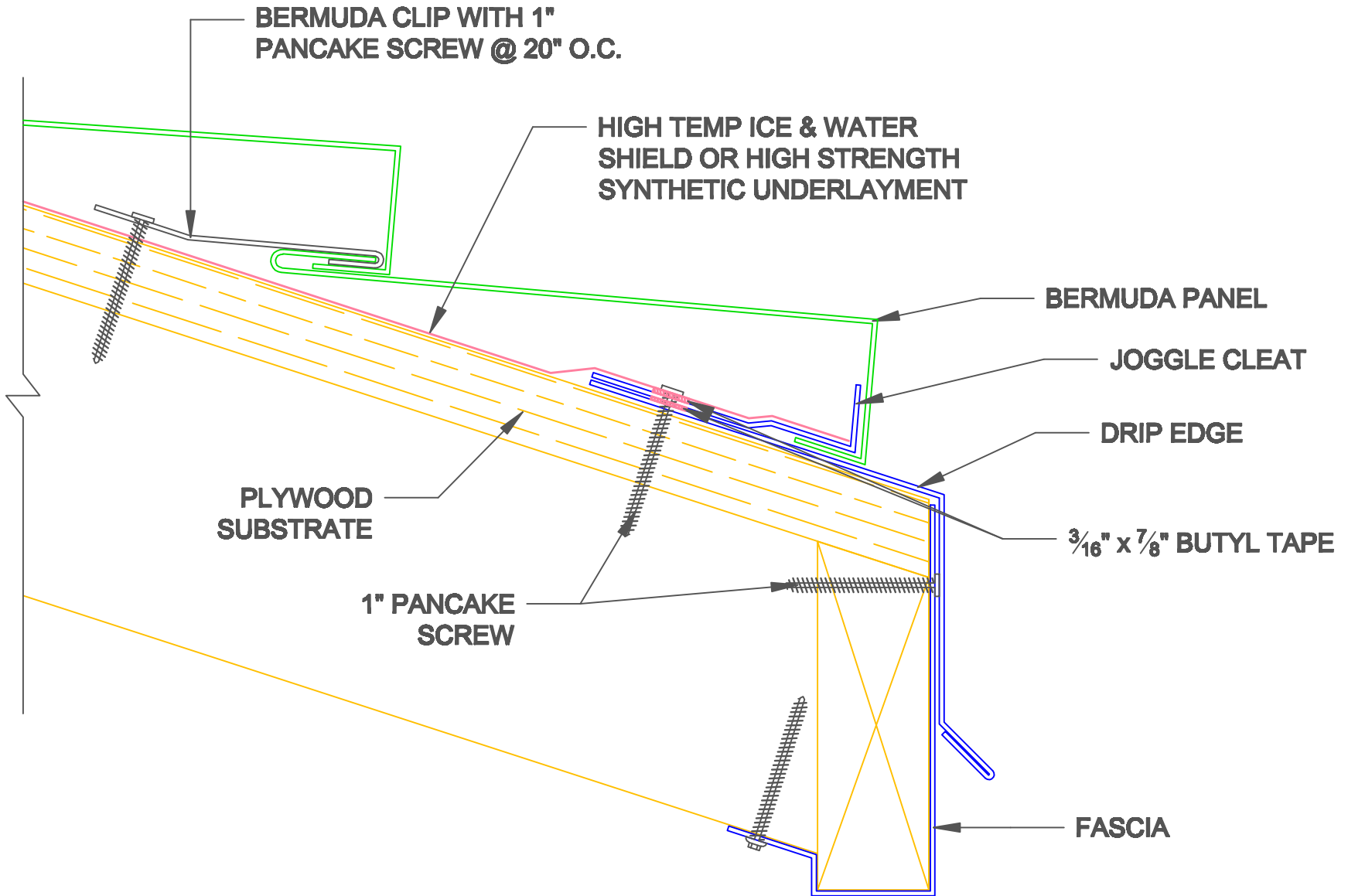

BERMUDA DRIP EDGE W/ JOGGLE

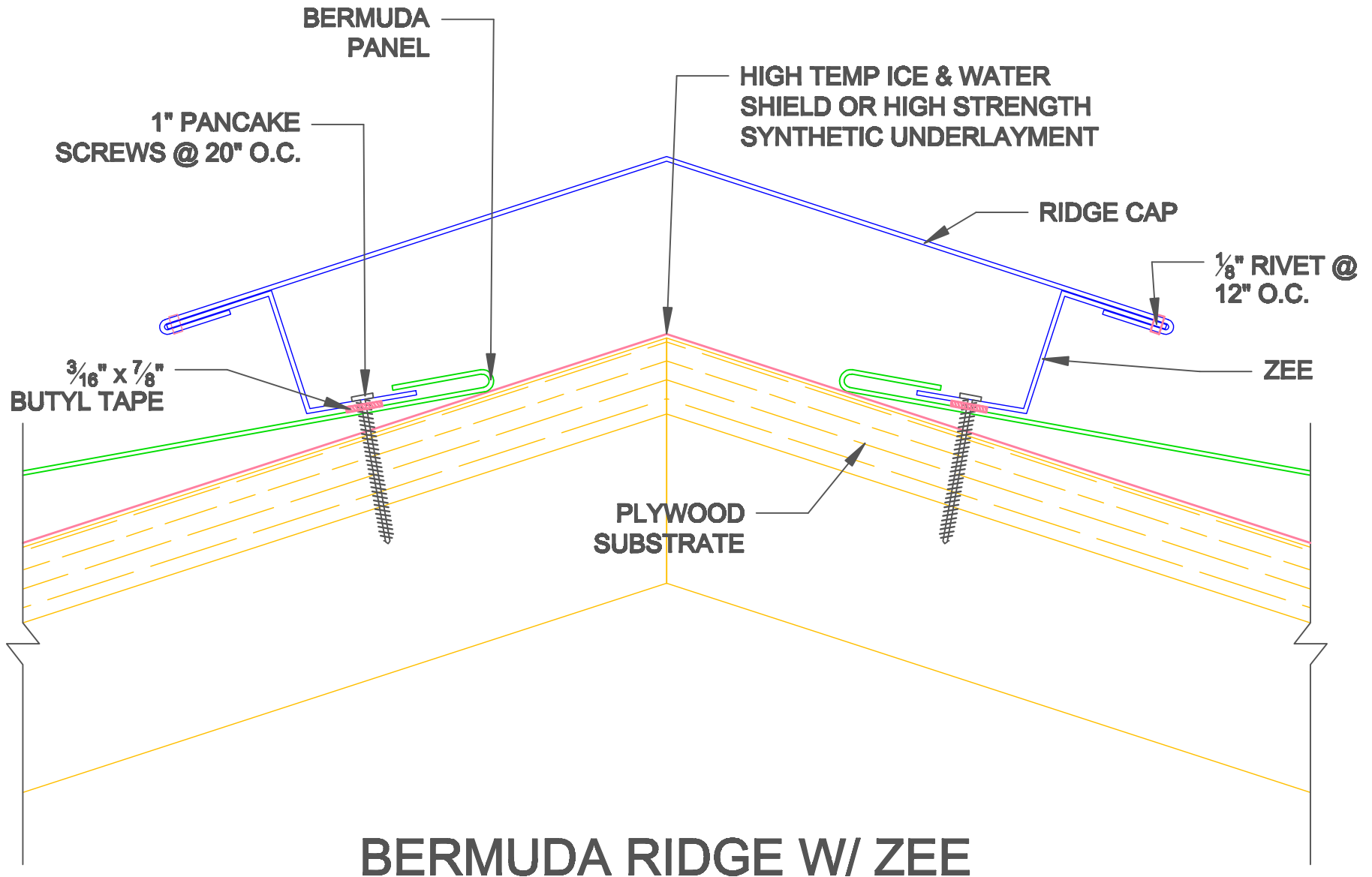

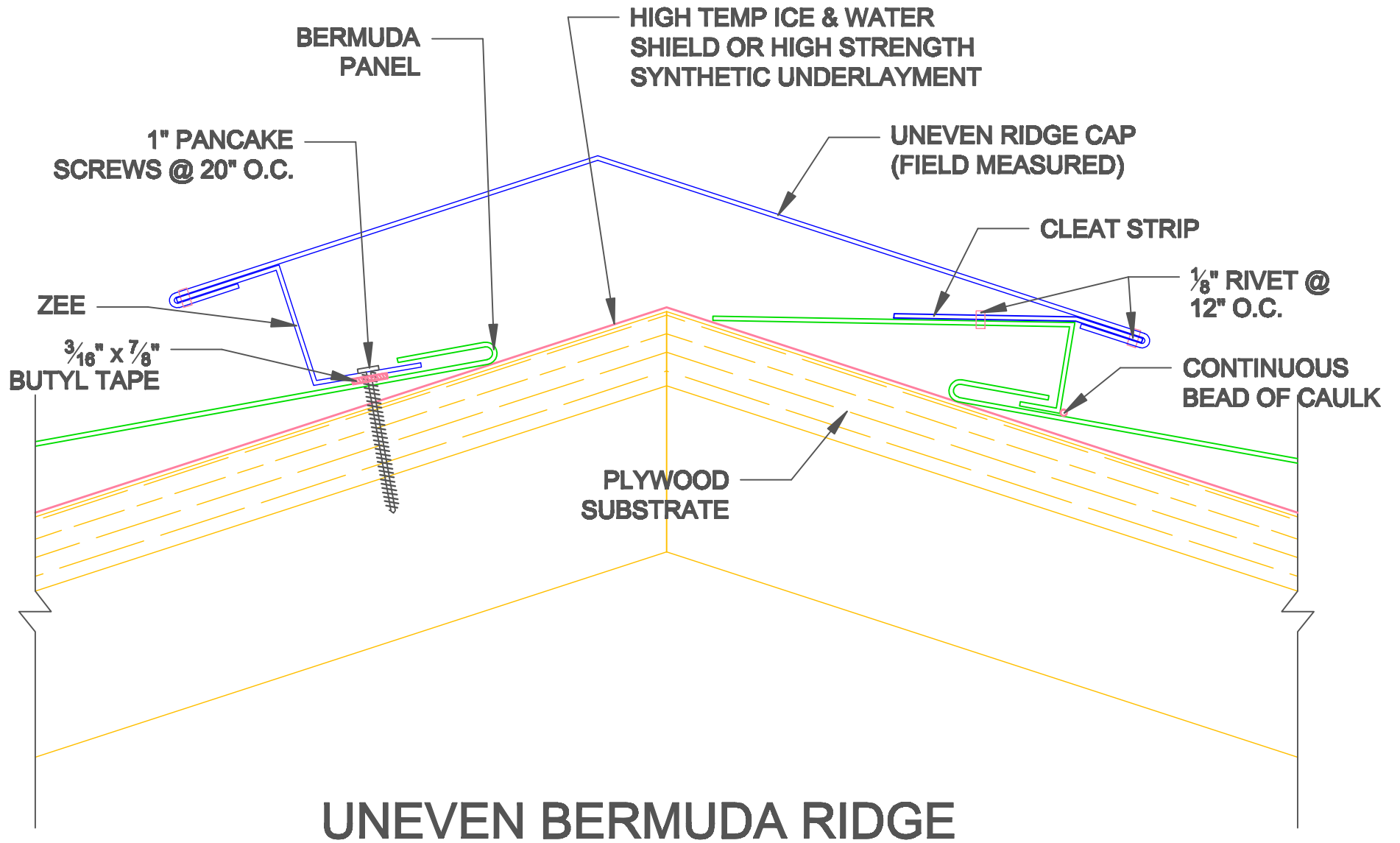

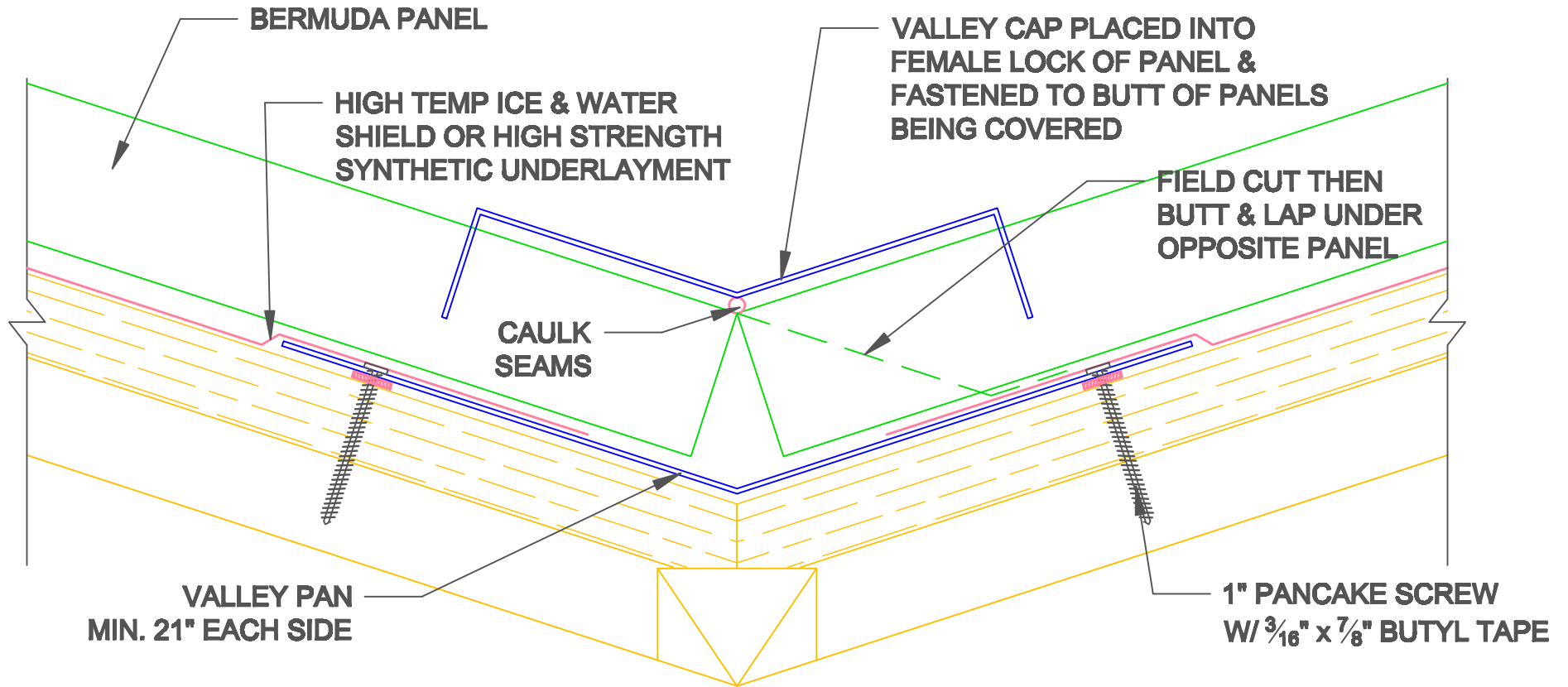

BERMUDA VALLEY

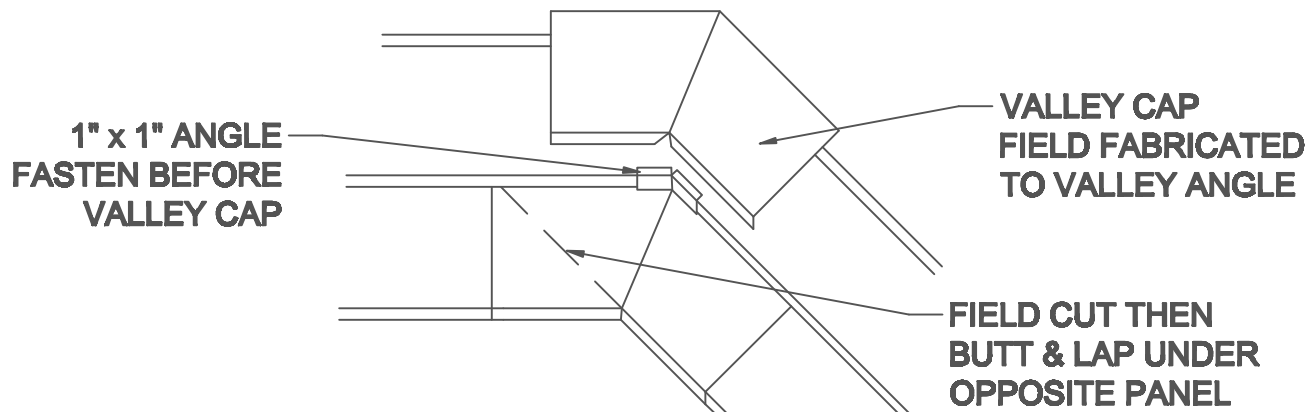

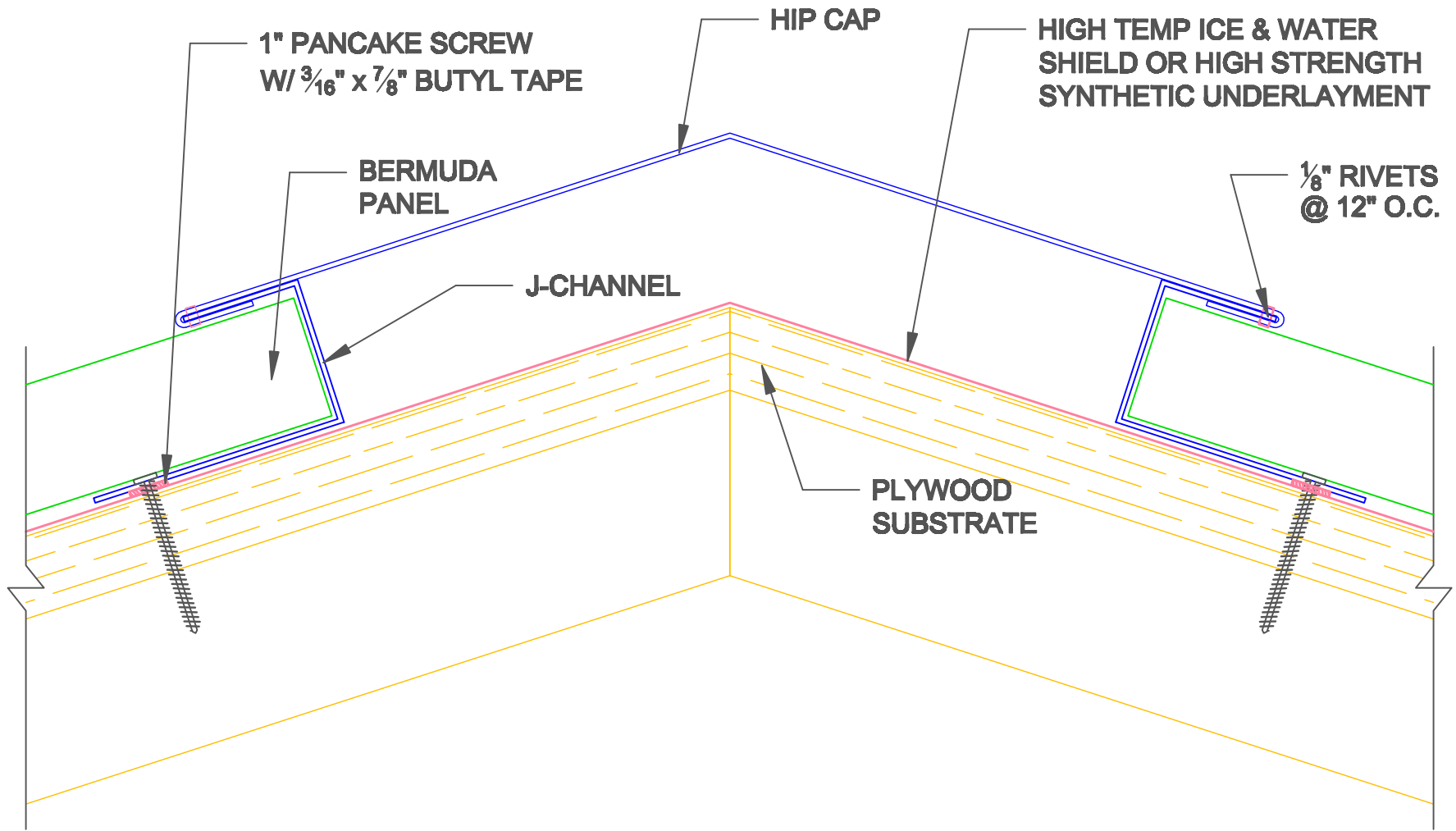

BERMUDA HIP W/ J-CHANNEL

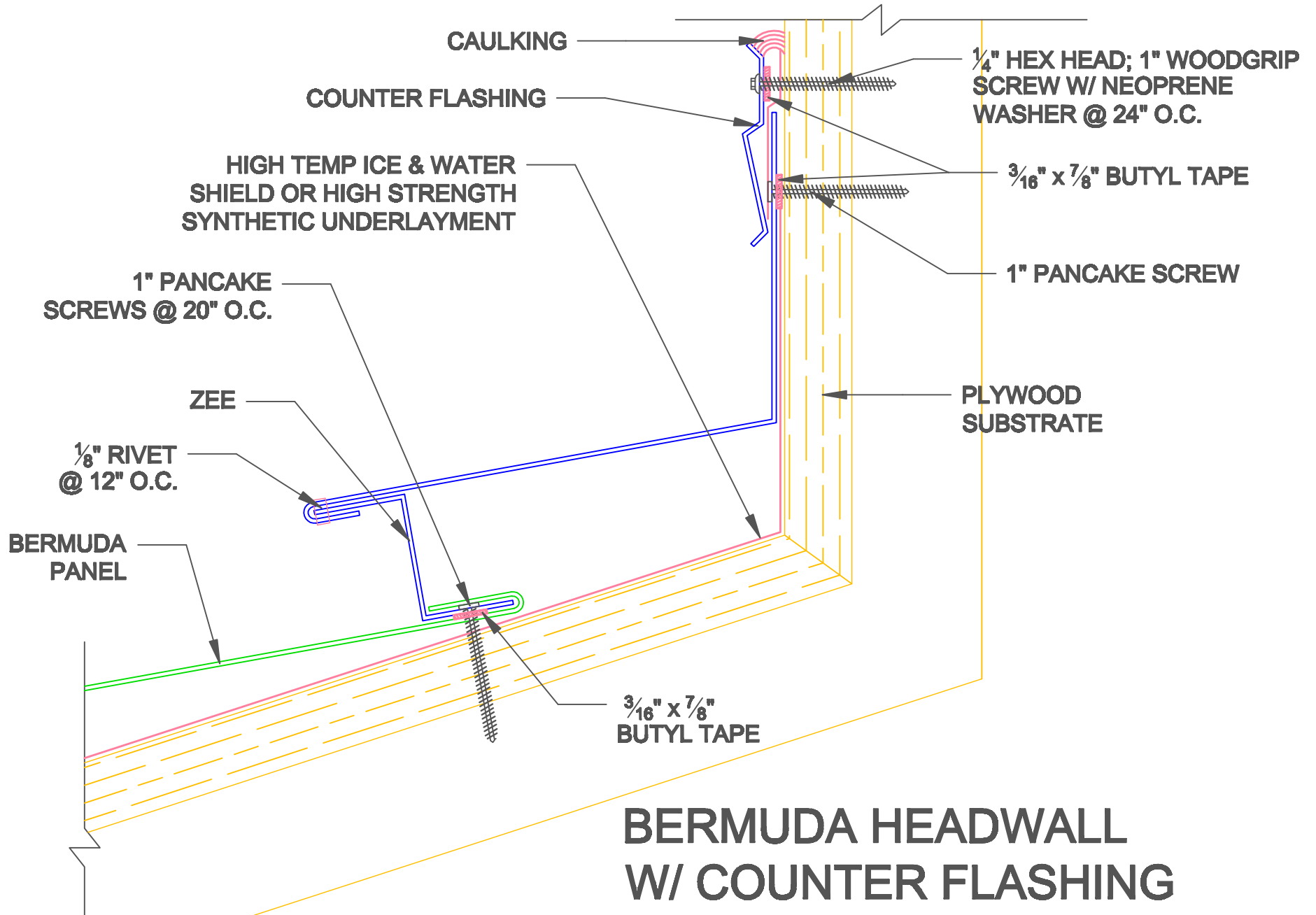

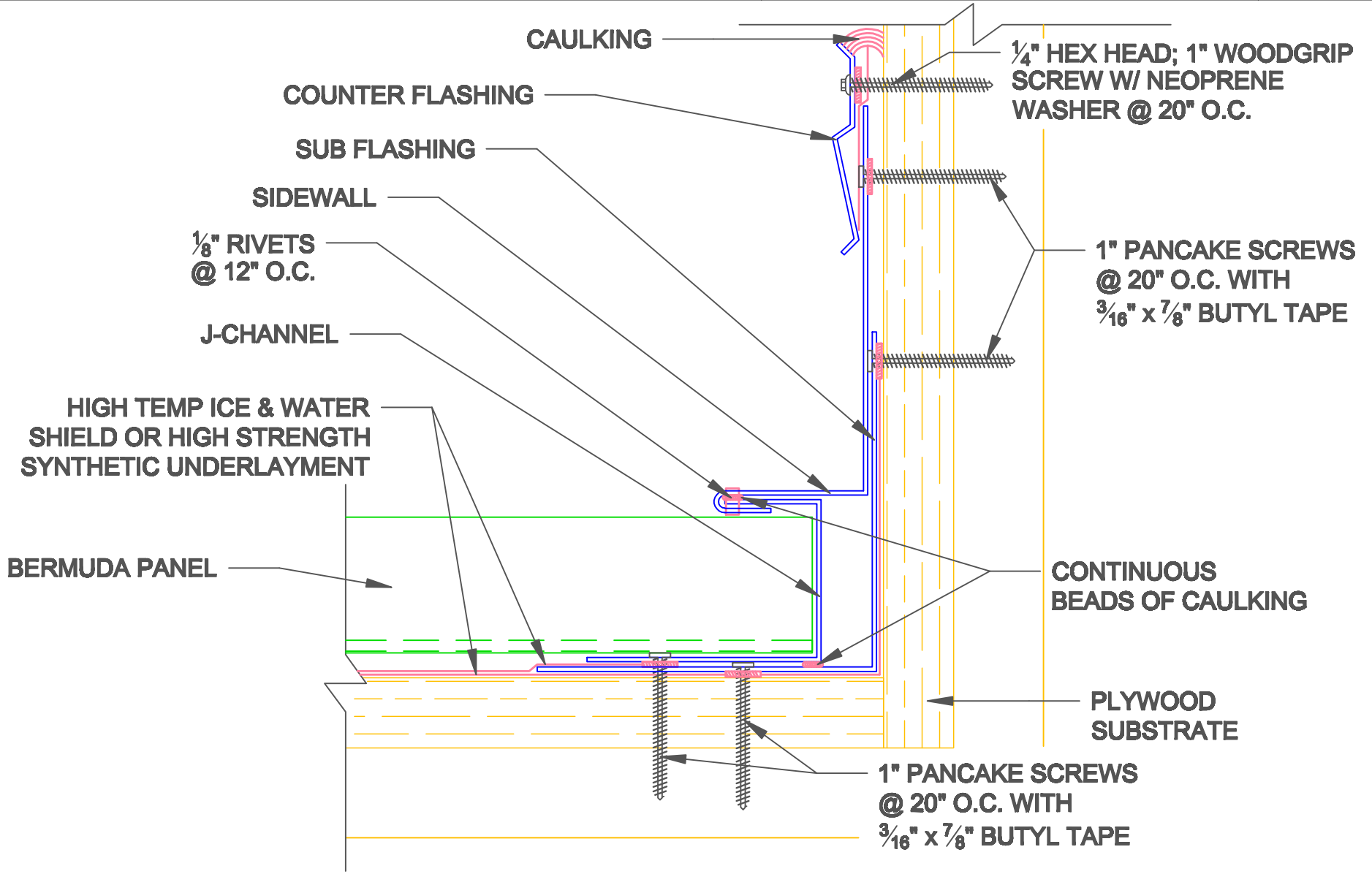

BERMUDA SIDEWALL W/ COUNTER FLASHING

CURB DETAIL

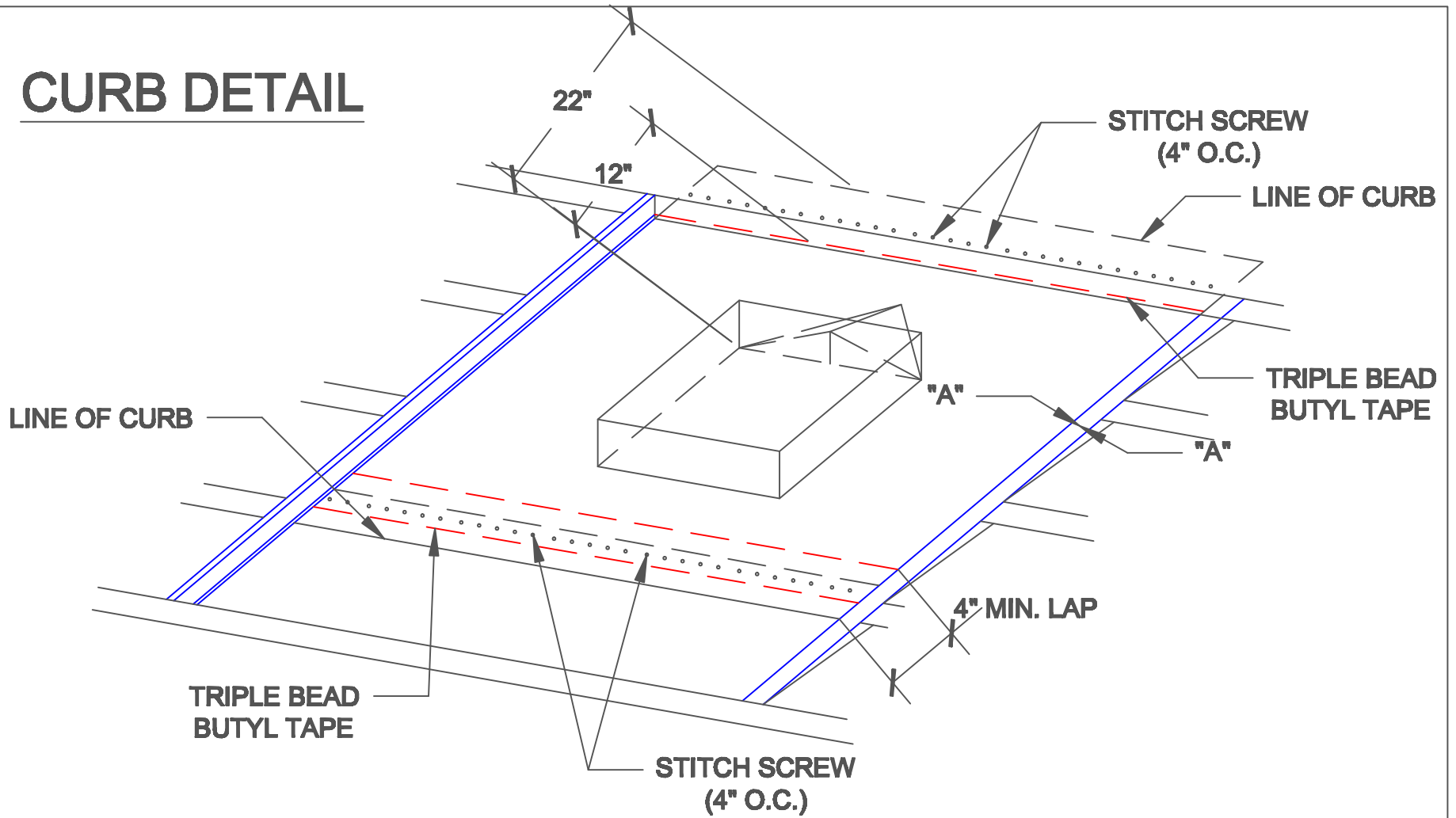

SECTION "A-A"

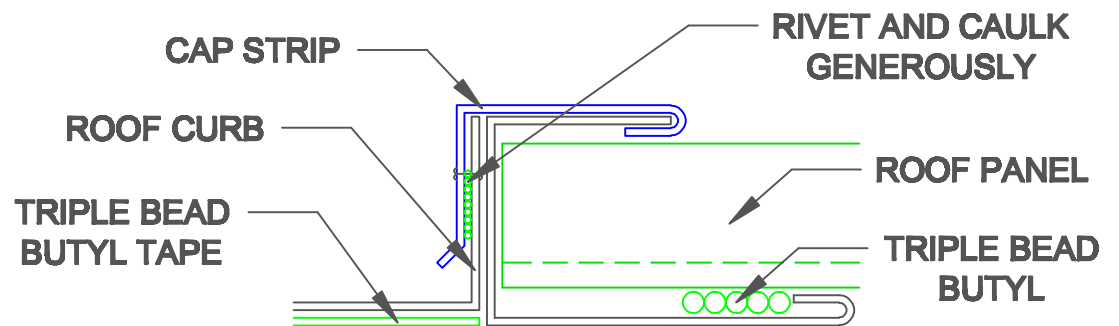

DECKTITE DETAIL

Use if pipe falls in field of panel.

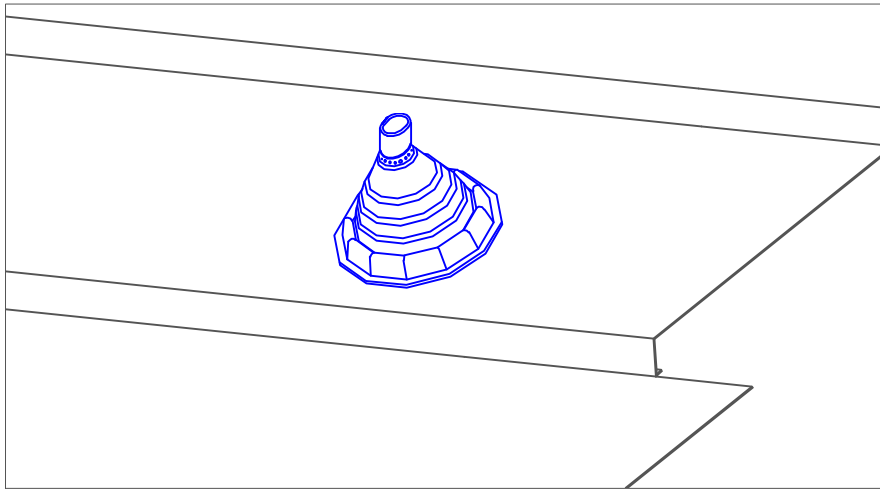

Use if pipe falls on panel ribs.

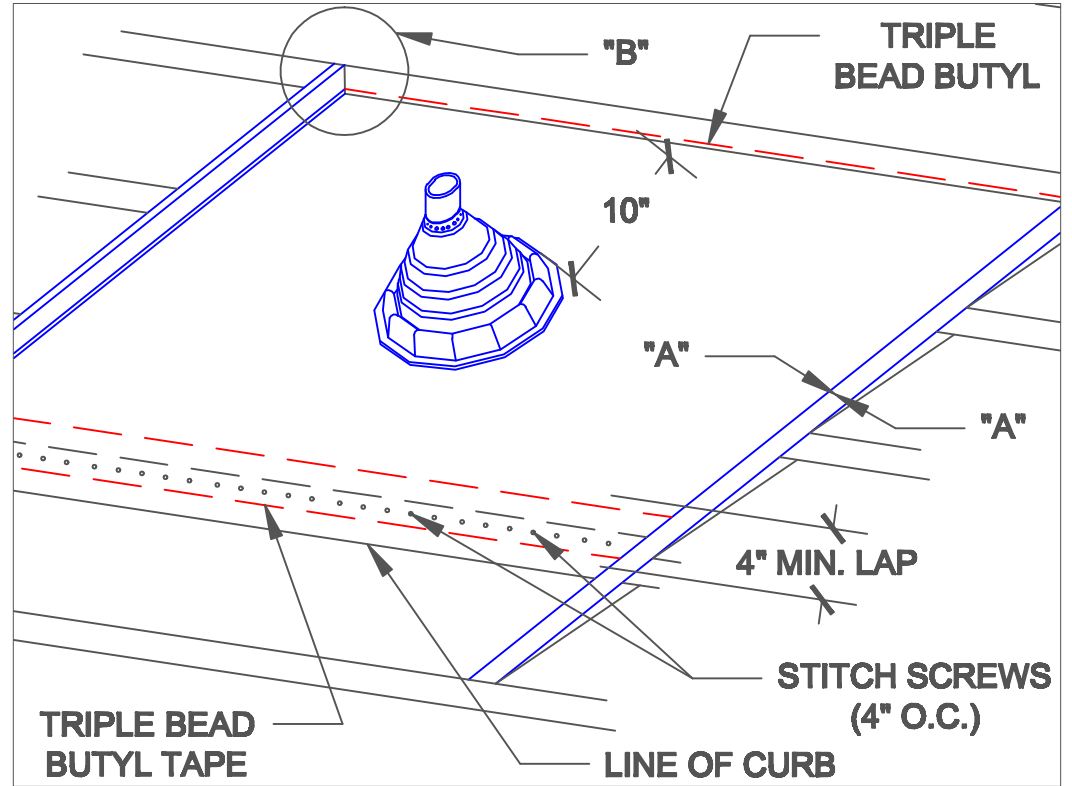

DETAIL "B"

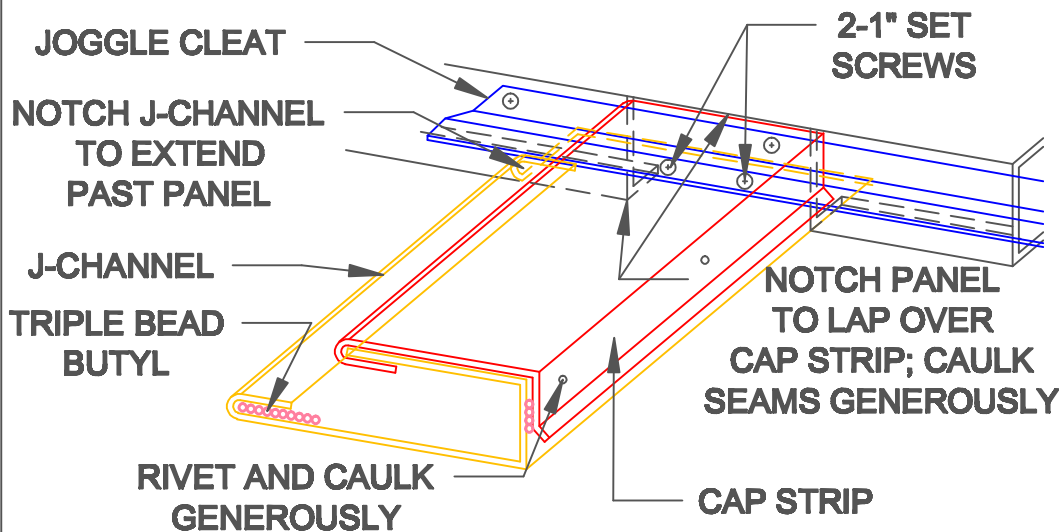

SECTION "A-A"

