

SOFFIT/WALL

PREMIUM PANELS INC.

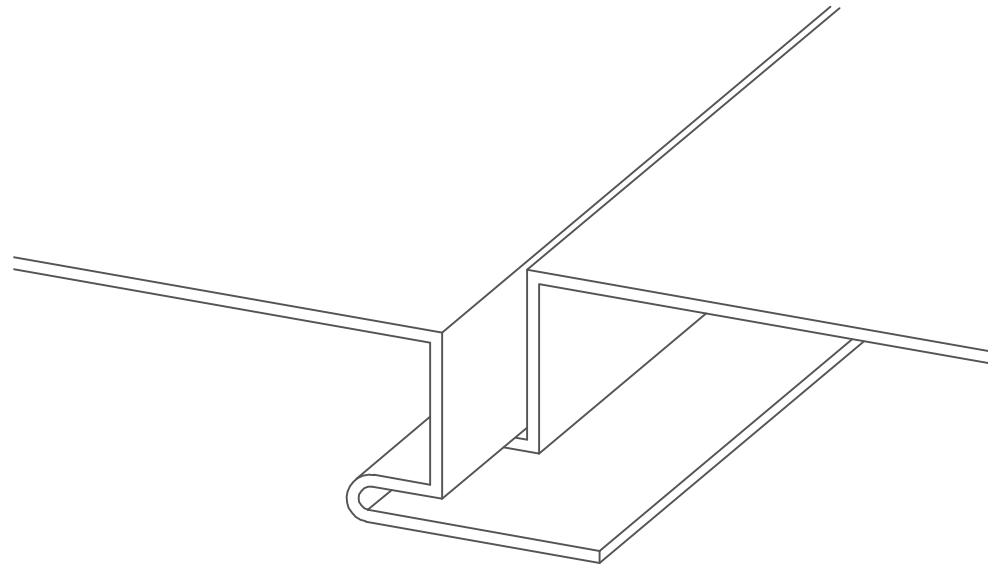

PLYWOOD DECK DETAILS

NOTES:

-MATERIAL USAGE: APPROX. 4"

WHEN USING PERFORATOR:

-MAX NET FREE AREA = 2.65 SQ. IN.

PER FOOT OF PERFORATION

-MAX OF 2 PERFORATIONS PER PANEL

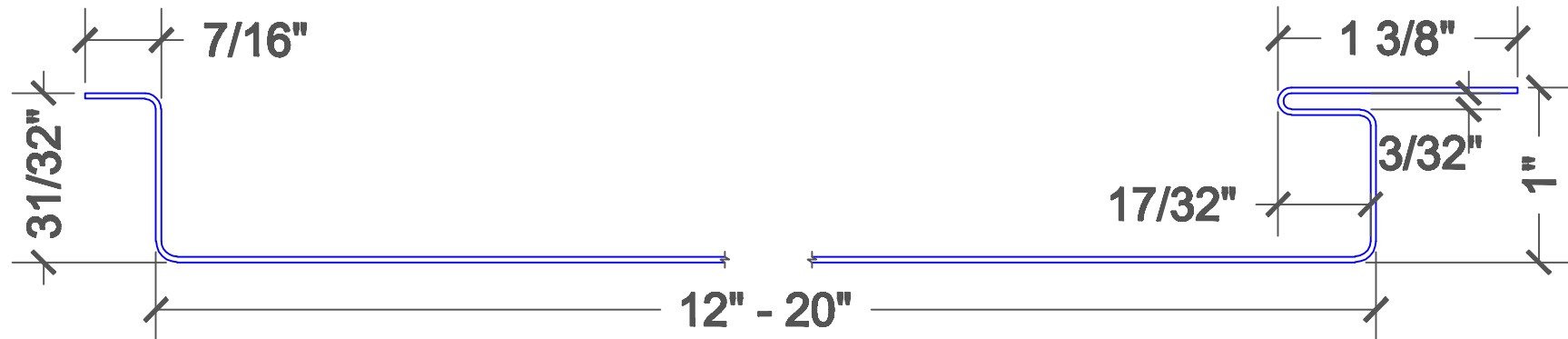
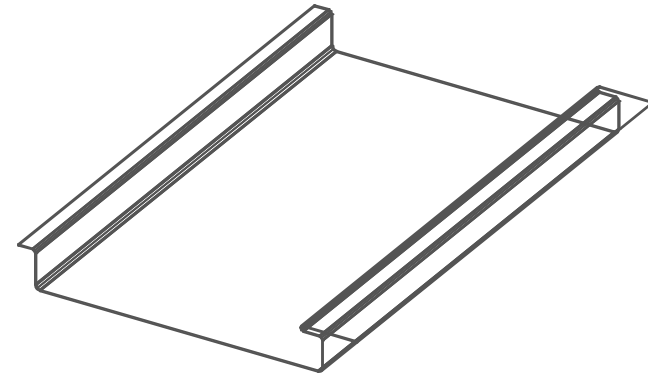

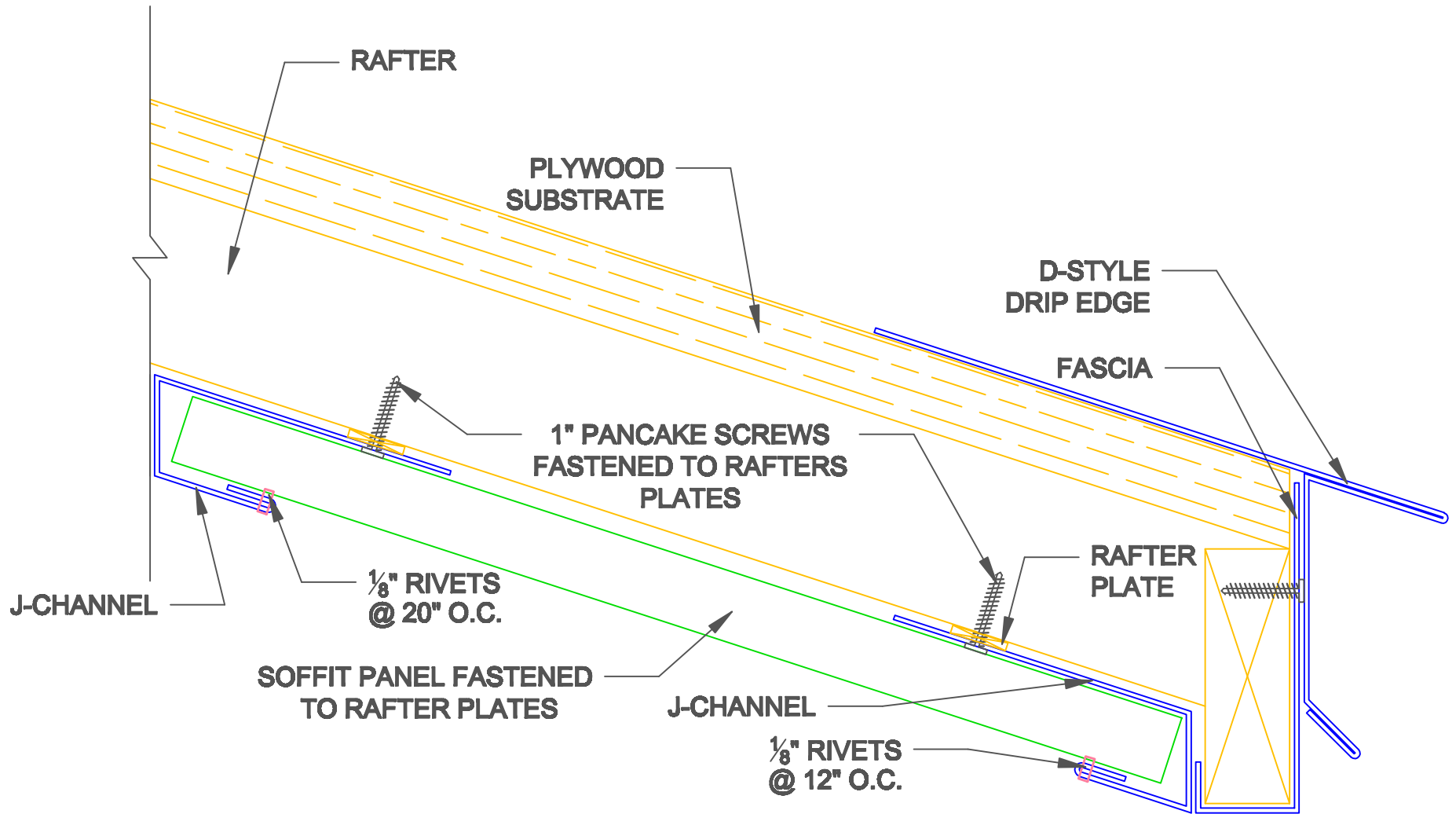

EAVE SOFFIT W/ J-CHANNEL

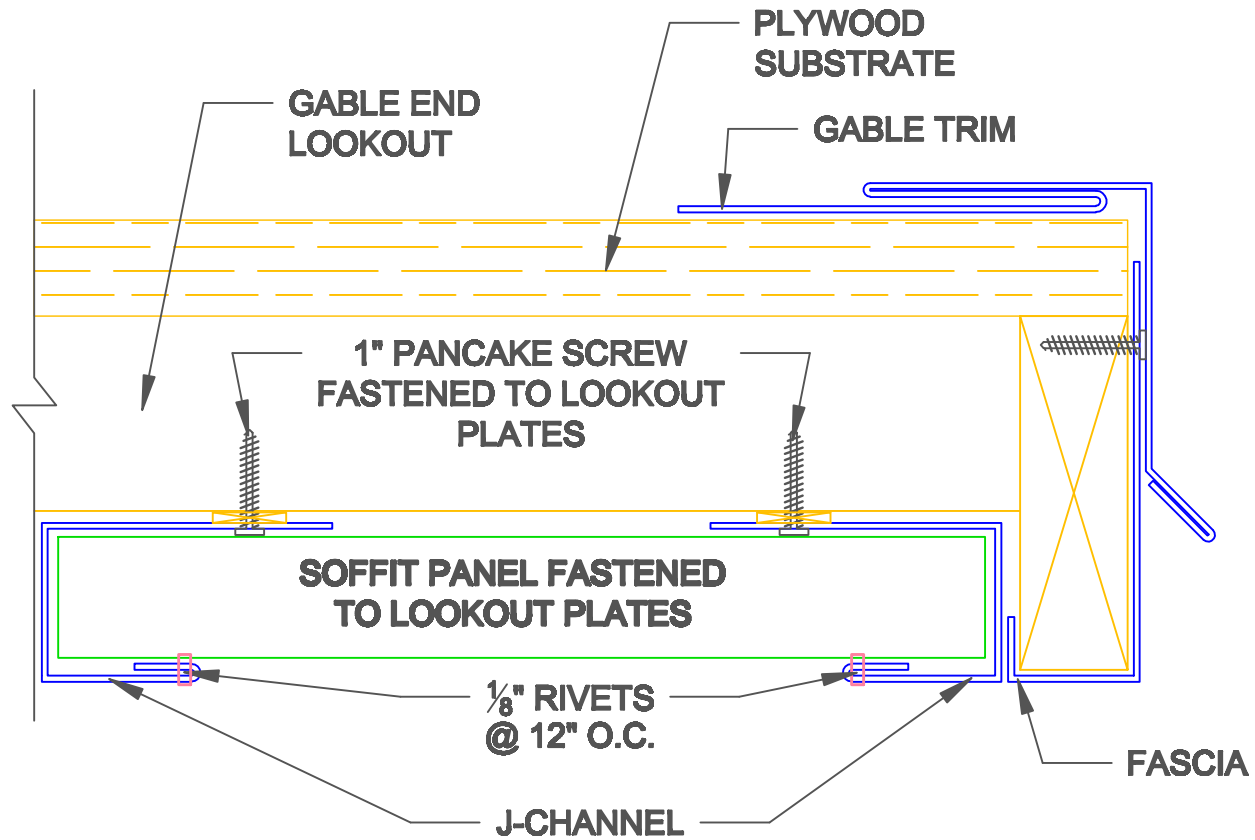

GABLE SOFFIT W/ J-CHANNEL

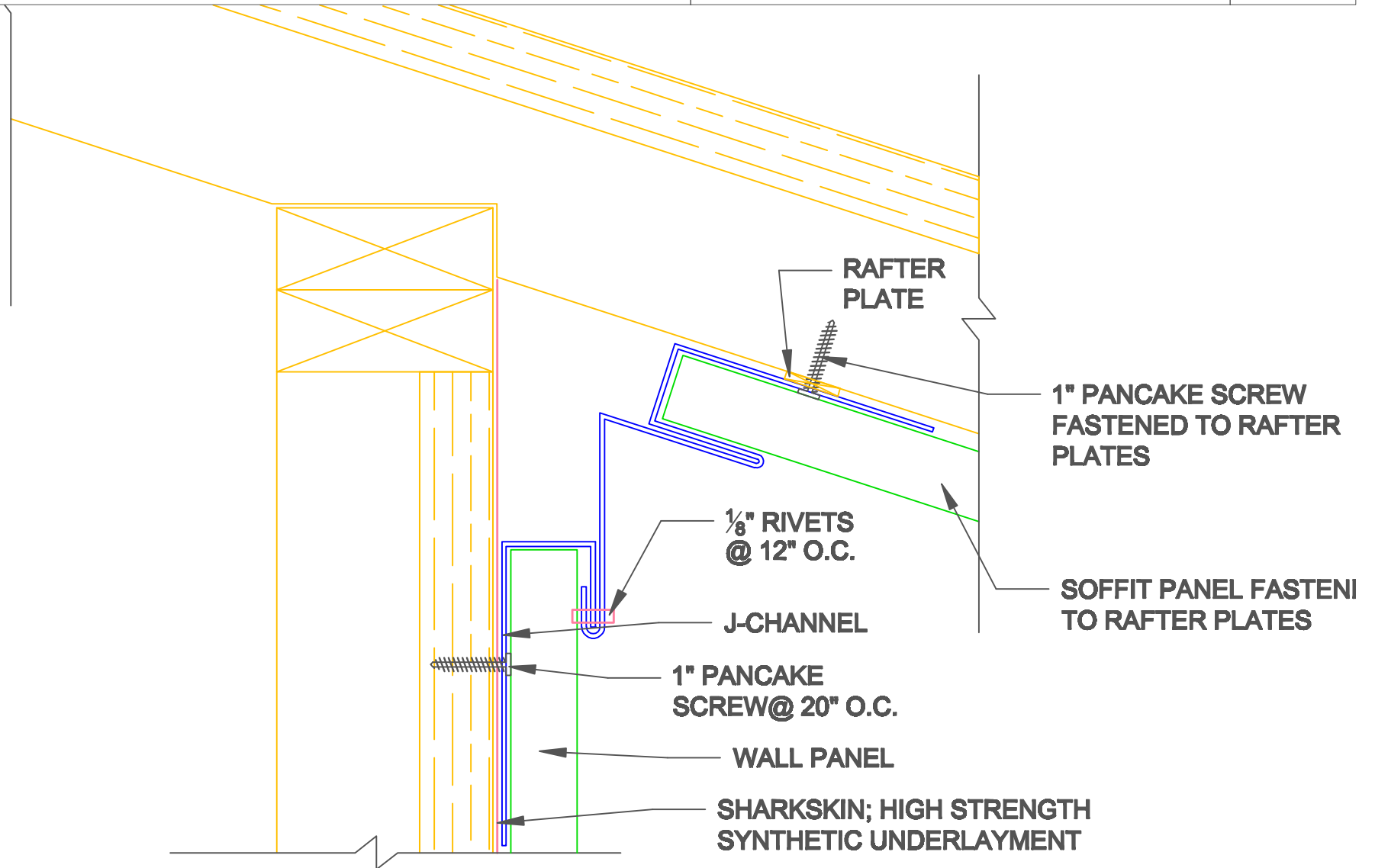

TOP TERMINATION OF WALL PANEL

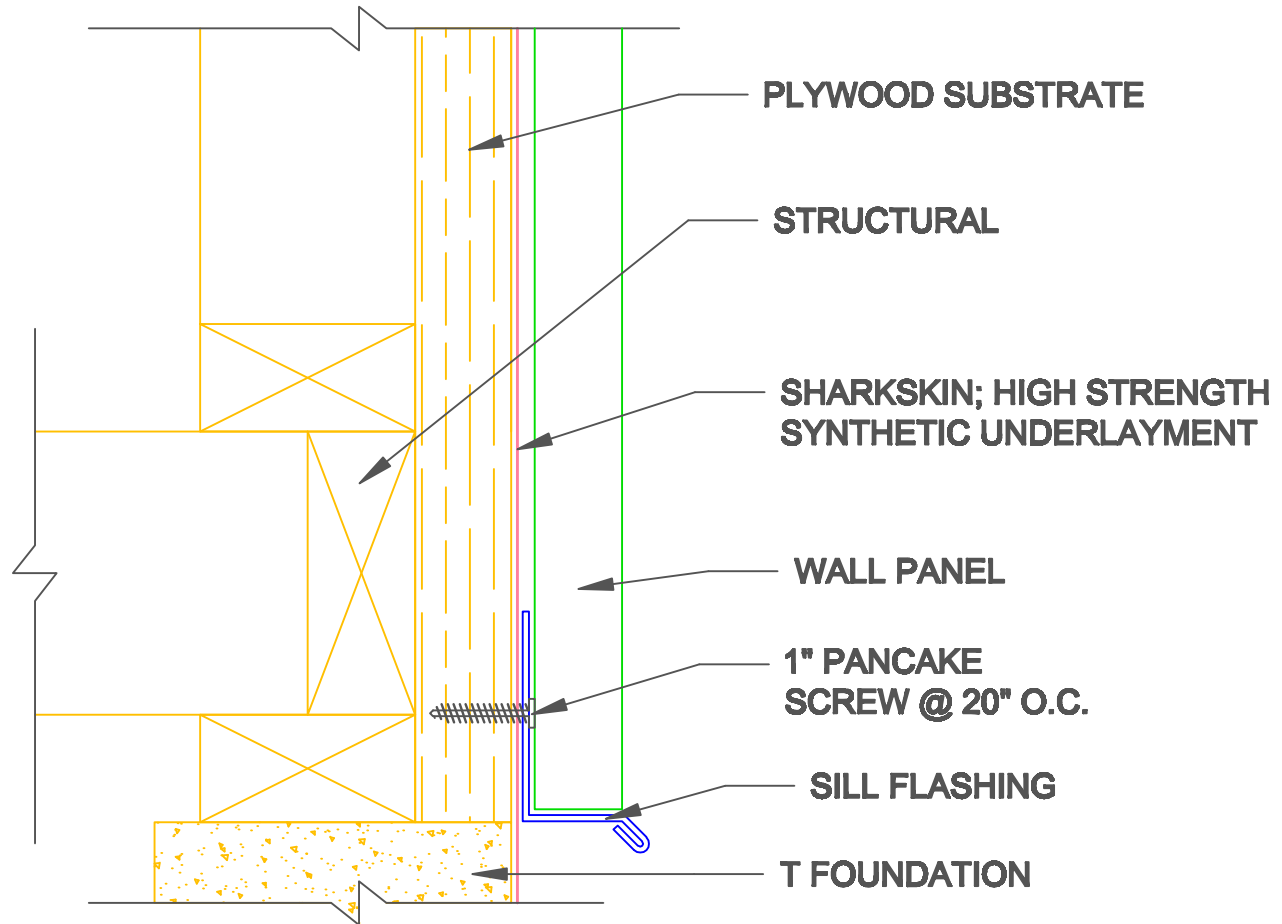

BOTTOM TERMINATION OF WALL PANEL

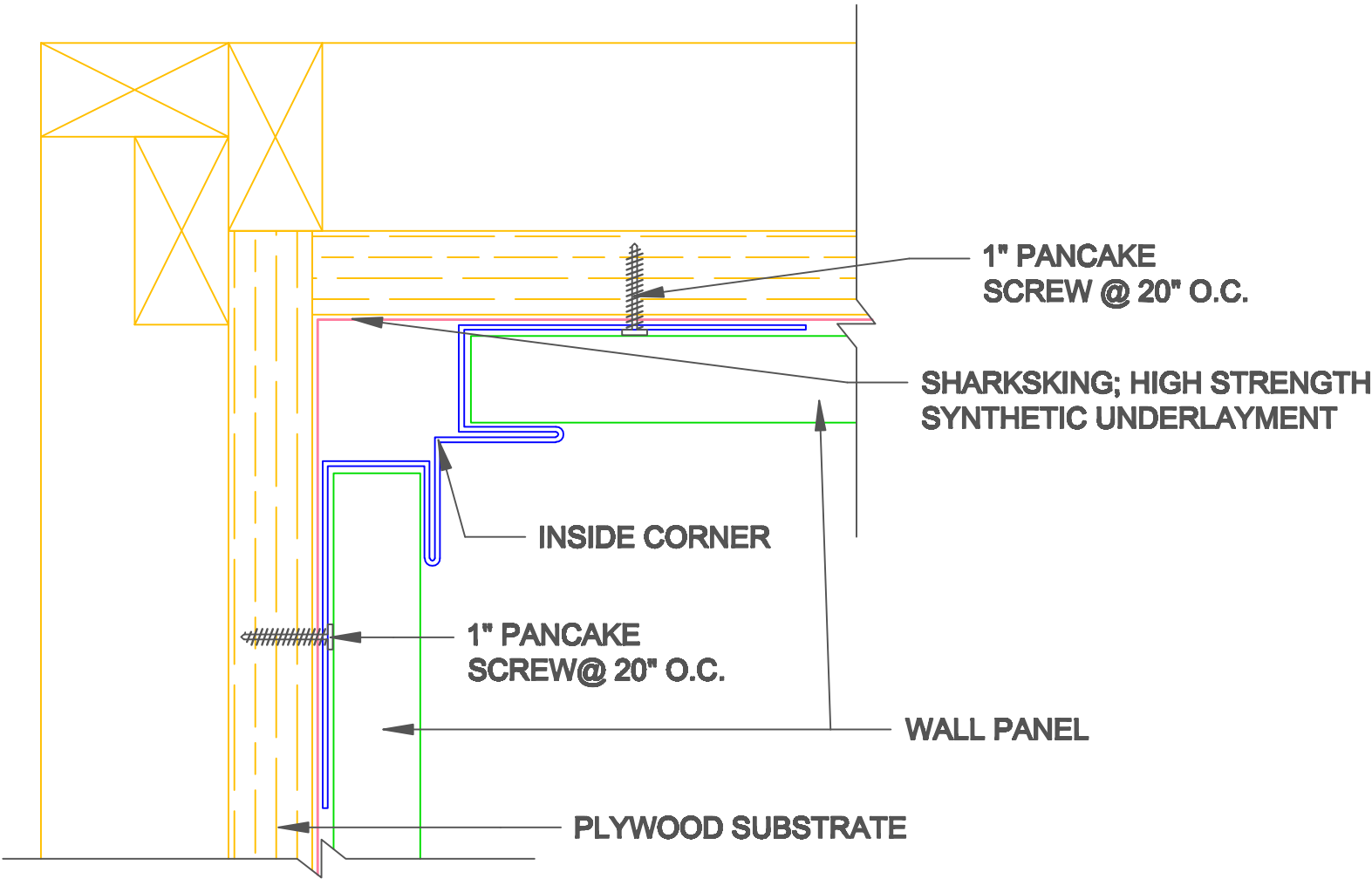

WALL PANEL INSIDE CORNER

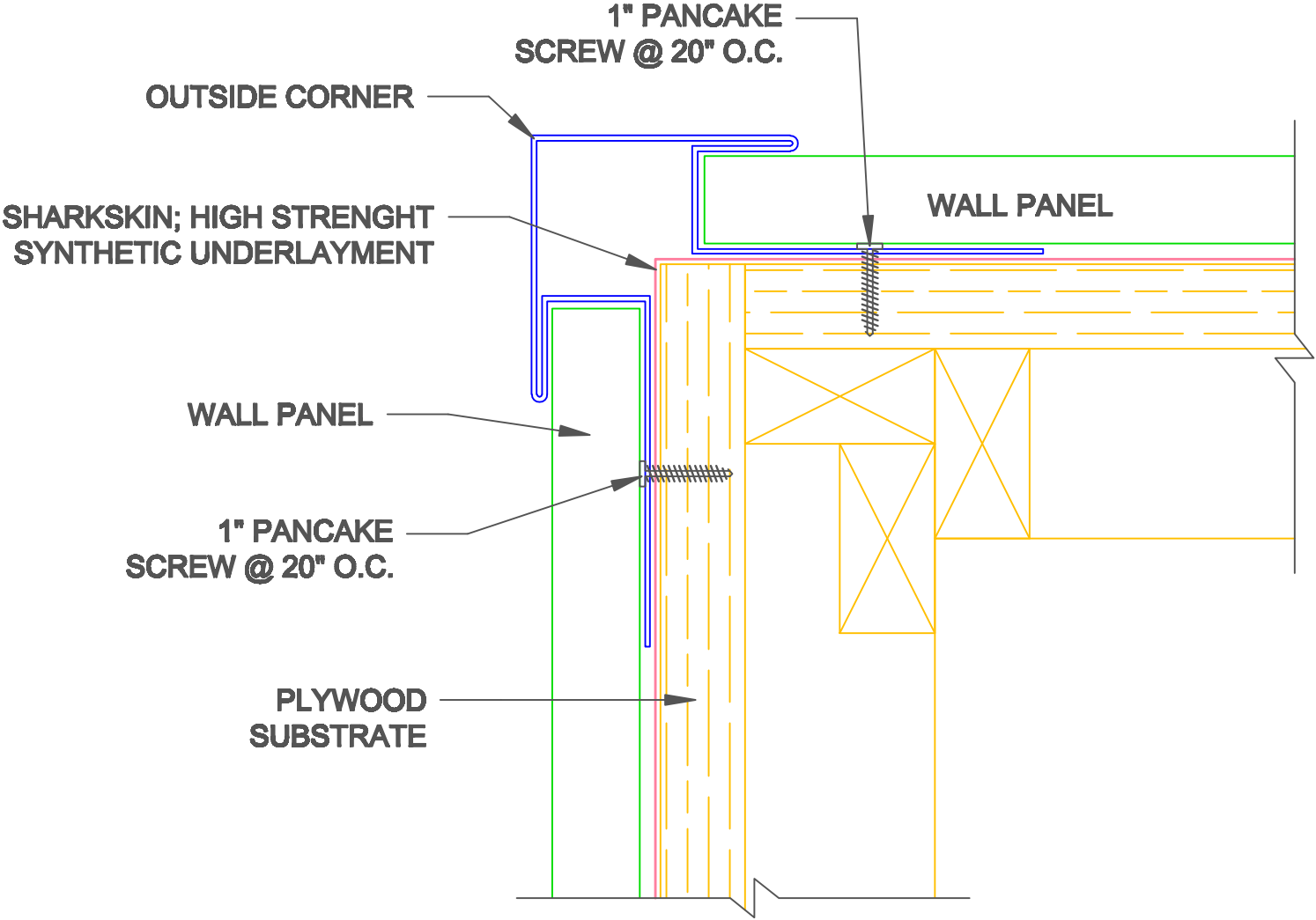

WALL PANEL OUTSIDE CORNER